

# User Manual

## 505U Radio Telemetry Module

*ELPRO Technologies Pty Ltd, 9/12 Billabong Street, Stafford Q 4053, Australia.  
Tel: +61 7 33524533 Fax: +61 7 33524577 Email: sales@elpro.com.au  
Web: www.elpro.com.au*

Thank you for your selection of the 505U module for your telemetry needs. We trust it will give you many years of valuable service.

## **ATTENTION!**

Incorrect termination of supply wires may cause internal damage and will void warranty.

To ensure your 505U enjoys a long life,  
**double check ALL your connections with  
the user's manual**  
before turning the power on.

## **WARNING**

1. For 505U modules, a radio licence is not required in most countries, provided the module is installed using the antenna and equipment configuration permitted. Check with your local 505U distributor for further information on regulations.
2. For 505U modules, operation is authorised by the radio frequency regulatory authority in your country on a non-protection basis. Although all care is taken in the design of these units, there is no responsibility taken for sources of external interference. Some delay in the operation of outputs may occur during periods of interference. Systems should be designed to be tolerant of these delays.
3. To avoid the risk of electrocution, the antenna, antenna cable, serial cables and all terminals of the 505U module should be electrically protected. To provide maximum surge and lightning protection, the module should be connected to a suitable earth and the antenna, antenna cable, serial cables and the module should be installed as recommended in the Installation Guide.
4. The 505U module is not suitable for use in explosive environments without additional protection.

# 505U Radio Telemetry Module USER MANUAL

<b>1</b>	<b>OVERVIEW</b>	<b>6</b>
1.1	AVAILABLE MODELS	6
1.2	INPUT SIGNALS	6
1.3	POWER SUPPLY	7
1.4	RADIO TRANSMITTER	7
1.5	CONFIGURATION	8
<b>2</b>	<b>OPERATION</b>	<b>9</b>
2.1	NORMAL OPERATION	9
2.2	WHAT INFORMATION IS TRANSMITTED OVER THE RADIO?	9
2.3	HOW OFTEN IS THE INPUT INFORMATION SENT BY RADIO?	9
2.3.1	<i>Digital Inputs</i>	10
2.3.2	<i>Pulse Inputs</i>	10
2.3.3	<i>Analogue Inputs</i>	11
2.3.4	<i>Setpoint Status</i>	13
2.3.5	<i>Low Battery Voltage Alarm</i>	13
2.3.6	<i>Communications Failure</i>	13
2.4	HOW TO DESIGN A REMOTE MONITORING SYSTEM	14
2.4.1	<i>Achieving reliable radio transmission</i>	14
2.4.2	<i>How far will the radio transmit?</i>	15
2.5	CALCULATING POWER CONSUMPTION	16
<b>3</b>	<b>HARDWARE INSTALLATION</b>	<b>19</b>
3.1	HOW TO MOUNT THE 505U	20
3.2	ANTENNA INSTALLATION	20
3.3	CONNECTION PLUG	24

---

3.4	POWER SUPPLY INSTALLATION.....	26
3.4.1	External Power (Models 505U-x-E).....	26
3.4.2	Internal Battery Power (Models 505U-x-B).....	26
3.5	INPUT SIGNAL CONNECTIONS.....	28
3.5.1	Digital/Pulse Inputs.....	28
3.5.2	Shaft Encoder Connections.....	29
3.5.3	Analogue input (505U-2 only).....	29
3.5.4	RS232 serial port.....	29
<b>4</b>	<b>CONFIGURATION-----</b>	<b>31</b>
4.1	I/O MAPPING.....	32
4.2	UPDATE TRANSMISSION TIMES.....	32
4.3	DIGITAL INPUTS.....	33
4.4	ANALOGUE INPUT.....	33
4.5	ANALOG SETPOINTS.....	34
4.6	PULSE INPUTS.....	35
4.7	NUMBER OF TRANSMISSIONS.....	36
	PROGRAMMING CONFIGURATIONS TO MODULES.....	36
4.9	LOADING CONFIGURATION FROM A MODULE.....	37
4.10	PRINT OPTIONS.....	37
<b>5</b>	<b>TROUBLESHOOTING-----</b>	<b>38</b>
<b>6</b>	<b>SPECIFICATIONS-----</b>	<b>41</b>
<b>7</b>	<b>WARRANTY-----</b>	<b>45</b>

# 1 OVERVIEW

The 505U radio telemetry module is an economical solution for the remote monitoring of process signals. The 505U can connect to digital, pulse or analogue signals from process transducers, and transmit these signal values by radio.

Although the 505U is intended to be simple in its application, it also provides many sophisticated features. This manual should be read carefully to ensure that the modules are configured and installed to give reliable performance. The 505U uses the 105U module as a receiver, or repeater. If you have not used 105U modules before, please read the 105U User Manual prior to reading this manual.

The 505U module is a monitoring only unit - that is, it will **only accept input signals** and does not provide output signals. The 505U has an internal radio transmitter; it does not have a receiver to receive messages from another module.

The 505U transmits the value of an input signal whenever the signal changes, and also after a pre-configured time. Each transmission message includes error-checking to confirm the validity of the message. At each transmission, the 505U may be configured to repeat the transmission several times to ensure that the transmission is received correctly. This is important if the radio path is marginal (that is, the radio signal is not strong) or if there is a lot of radio traffic on the radio channel which may corrupt the 505U message. The 505U transmits the input message to a 105U module, which sets an output signal to be the same value as the 505U input, or the 105U passes the input message to another device (PC or PLC) via its serial port.

For more information on the 105U module, please refer to the 105U User Manual.

## 1.1 Available Models

The 505U has a heavy duty painted aluminium enclosure, weather-proof to IP66. Signal and power connections to the unit are made via a weatherproof connector at the bottom of the module. Antenna connection is made using a BNC coaxial connector at the top of the module.

### External 12VDC supply

505U-2-E      two digital/pulse inputs plus one analogue input

### 3.5 – 5VDC battery supply (*batteries not included*)

505U-2-B      two digital/pulse inputs plus one analogue input

## 1.2 Input Signals

The 505U-2 model provides two digital/pulse inputs and one analogue input for connecting to process transducers.

### *Digital* Signals

---

Examples: motor fault, tank overflow, intruder alarm

**Pulse** signals - use the same input as the digital input

Examples: electricity metering, fluid flow, raingauge

**Analogue** continuously variable signals (0-20mA, 4-20mA, 0-10mA) - *505U-2 only*

Examples: measured tank level, measured process temperature

Two **internal** signals may also be transmitted to outputs in the network:

- Setpoint Status (digital signal set or reset depending upon the value of the analogue signal compared to a high and a low setpoint value configured in the 505U)
- Battery Low Voltage (digital signal set when internal battery voltage is low).

### 1.3 Power Supply

The power consumption of the 505U is very small as it conserves power by reverting to “sleep” mode between transmissions.

The 505U can be powered from an external 12V DC supply, or a 3.5 – 5V battery supply. The battery supply can be either internal AA alkaline or lithium batteries, or an external battery pack. The 505U-2-B units provide an internal alarm on low battery voltage - this alarm may be transmitted by radio for warning purposes. No low battery alarm is provided on externally powered models (505U-2-E). The low battery alarm indicates that there is approximately 2% of battery capacity left.

### 1.4 Radio Transmitter

The 505U has an internal radio transmitter that operates on unlicensed radio channels in the 400 – 500MHz UHF band. A radio licence is not required for the 505U in many countries and has an operating range of several kilometres.

It is suitable for use in utility industries such as electricity, water and gas, as well as a cost effective solution for short range applications in factories and industrial plants.

The transmitter is preset in the factory to suit the unlicensed frequency requirements in each country. The maximum transmitter power is 500mW using an external power supply, or 250mW using the internal battery supply (500mW available using a 3dB antenna). In countries where there are no unlicensed radio channels, a radio licence may be required each time the product is used. Please contact one of our worldwide distributors for further information.

To **extend radio range**, 105U modules can be used as repeaters. Up to five repeaters can be configured for each input-to-output link. The configuration is done at the 505U module where the input signal is - no additional configuration is required at the 105U modules. The transmitted radio message will include the address of repeater modules - modules with these addresses will re-transmit the messages.

## 1.5 Configuration

Each module must be configured before it can be used. Configuration is performed using a PC (or a laptop computer) connected to the module via the internal RS232 port on the 505U. 505U configuration software is required and is provided with each order.

Configuring a module requires the entering of “input mappings” and setting operating parameters for each input. An “input mapping” links an input signal to an output channel at a remote module (or a “destination address”). An input mapping is entered for each input signal (external and internal) which is used.

## 2 OPERATION

### 2.1 Normal Operation

Once configured using the 505U configuration software, the 505U module will normally be in “sleep” mode to conserve power. During sleep mode, the microprocessor controller powers down, and the analogue loop supply is turned off. The microprocessor will automatically “wake up” and revert to full operation if a digital/pulse input changes (*on to off*, or *off to on*), or every 0.5 seconds to check if a timed update transmission is due to be sent.

Normal operation of the 505U is indicated by a brief flicker of the OK LED light on the front panel approximately every 10 seconds.

### 2.2 What information is transmitted over the radio?

The 505U modules transmit the value of the input signal in a data frame. The data frame includes a system address, and the "address" of the transmitting (source) 505U module and the receiving (destination) 105U module, so that each transmitted message is acted on only by the correct receiving unit. The system address is a common address used by all modules in the same system. This allows multiple systems to operate within the same radio range without "cross-talk" between systems.

The user configures these addresses as part of the module configuration. Each transmitted message also includes error checking to ensure that no corruption of the data frame has occurred due to noise or interference. If repeater modules are being used, then the addresses of these intermediate modules are also included in the data frame.

The user can configure the 505U to transmit each message from one to five times to ensure that at least one of the messages is received correctly. Each repeat transmission will occur at random intervals between one and four seconds.

### 2.3 How often is the input information sent by radio?

- Change messages. The 505U transmits the value of an input signal whenever the signal changes.
- Update messages. The input value is also transmitted if the signal has not changed within a pre-configured update time (configurable 10 seconds to 5 days).
- Paralysis. When a 505U transmits a message for a particular input, the 505U will not transmit another message for this input within a configured time period. This time is called the paralysis time, and may be used to prevent a lot of messages being transmitted if an input changes frequently. The paralysis time may be set from zero to 127.5 seconds for each input. For example, assume the paralysis time on an input is 30 seconds. If the input changes, then the 505U will transmit a message, however it will not transmit another message for this input during the next 30 seconds, regardless of changes to the input signal. Note that paralysis time does not

stop re-transmissions of each message - if the 505U is configured to transmit each message three times, then paralysis will not stop this.

Depending on the type of input signal (digital, pulse or analogue), the 505U must determine what type of signal change is required to send a transmission:

### 2.3.1 Digital Inputs

A digital input can be an external digital input or an internal status input (setpoint status or low battery alarm).

The 505U will transmit the value of the digital input whenever it changes from off to on or from on to off. A paralysis time may be configured to prevent another transmission within this time. The 505U will also transmit an update message if a message has not been transmitted for that input within an "update time".

There are two update times for each digital input - one for when the input is on, and one for when the input is off. Each update time may be configured between 10 seconds and 5 days. For example, a digital input may be configured to update every 1 day when the input is off, but update every 10 minutes when the input is on. If an update time of zero (or less than 10 seconds) is selected, then no update messages will be sent.

Overview:

- Input value transmitted on input change
- Update message if the input value has not been transmitted within the configured update time for that input (10 seconds - 5 days)
- Separate update times for on and off status for digital inputs
- After each transmission, further transmission for that input is disabled for the paralysis time (0 – 127.5 sec).

### 2.3.2 Pulse Inputs

Each pulse input is counted and the total count value is transmitted as a 16-bit value. A "sensitivity" value is configured for each pulse input (0 - 32 000). Whenever the pulse count has increased by this value since the last transmission, the 505U will transmit the new pulse count. In addition, an update transmission of the pulse count will be transmitted if the pulse count has not been transmitted for the update time. If an update time of zero is selected, then no update messages will be sent.

When the 105U receives the input count message, it will compare the input count to its own output count (the count of output pulses), and will then output pulses until the two counts are the same.

The maximum pulse input is 100Hz (3 msec minimum on-time and off-time). There is no minimum pulse rate. For pulse rates higher than 1Hz, the power consumption will increase slightly. For pulse rates higher than 10 Hz, the "Fast Pulsed Inputs" option should be selected. This increases power consumption of the module further.

If the pulse input message is sent to a host device, it is important to note that the count value transmitted is an absolute value. The only time that it resets is when the 16-bit accumulator "rolls over" (exceeds 65 535).

Overview:

- Pulse inputs are counted.
- Pulse count is transmitted when the count has increased by the sensitivity amount since the last transmission.
- Update message if the input value has not been transmitted within the update time (10 seconds - 5 days).
- After each transmission, another transmission for that input is disabled for the paralysis time (0 – 127.5 sec).

Two pulse inputs may be configured to control one count value, for use with quadrature and incremental shaft encoders. A shaft encoder is a transducer that measures level or displacement, and has two pulse signals to indicate change of level and direction of change.

Both pulse inputs are read at the same time.

If using an incremental encoder, the count is the value of Pulse Input 1. This pulse input value should be used to send the true pulse count from a incremental encoder.

If using a quadrature encoder, the count is the value of Pulse Input 2. This pulse input value should be used to send the true pulse count from a quadrature encoder.

### 2.3.3 Analogue Inputs

The analogue input uses a "sample time" and "warm-up time" configured by the user. The sample time (1 minute to 20 days) "wakes" the 505U from sleep mode and turns on the analogue loop supply. The "warm-up time" (0.5 – 127.5 seconds) allows the transducer to reach rated accuracy before the 505U makes a measurement of the analogue signal.

For example, if the sample time is 30 minutes and the warm-up time is 10 seconds, then every 30 minutes, the 505U will turn on its analogue loop supply and after a further 10 seconds, take a measurement of the analogue signal. After the measurement is taken, the 505U reverts to sleep mode. The loop voltage available for a transducer is approx 1.5V less than supply voltage for externally powered models or 8.5V for battery powered models.

If the sample time is set to zero, then the analogue loop supply will be on continuously and measurement will be taken based on the warm-up time. If the warm-up time is 1 second, then a measurement is taken every 1 second.

The same process occurs if an externally powered analogue signal is connected.

The measurements have a resolution of 12 bit, and an overall accuracy of better than 0.1%.

When the 505U takes a measurement, it will transmit the analogue value if the value has changed by more than the pre-configured sensitivity since the last transmission. The sensitivity can be configured from 0.25% to 100% (0.05mA to 20mA) with a default value of 3% (0.6mA). If the change in the signal since the last transmitted value is less than the sensitivity, then the 505U will not transmit the analogue value.

In addition, an update transmission of the analogue value will be transmitted if the analogue value has not been transmitted for the update time (10 seconds - 5 days). If an update time of zero is selected, then no update messages will be sent.

If the update time expires since the last transmission, then the last measured value will be transmitted - that is, a new measurement will not be taken. Normally the update time will be much longer than the sample time. If the update time is less than the sample time, then update messages may transmit the same value as the previous transmission, as a new measurement has not yet been taken.

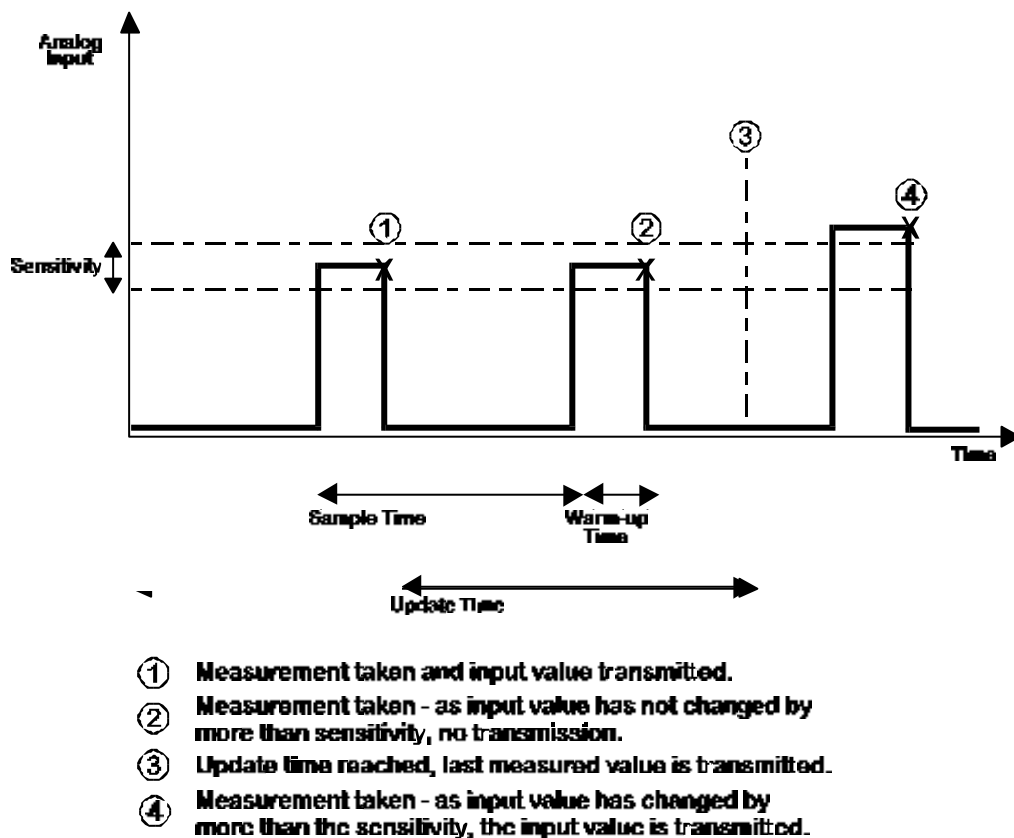

Overview:

- Measurements of the analogue signal are determined by the sample time and warm-up time
- Analogue value is transmitted if the measured value has increased by the configured sensitivity amount since the last transmission
- Analogue value is transmitted if the input value has not been transmitted within the update time (10 seconds - 5 days)

### 2.3.4 Setpoint Status

The setpoint status is an internal status value, calculated by comparing the analogue input to two configurable setpoint values. The setpoint status turns ON when the analogue input moves below the low setpoint value, and turns OFF when it moves above the high setpoint value. The high setpoint percentage must always be greater than, or equal to, the low set point.

The internal setpoint status will be determined every time an analogue measurement is taken.

The setpoint status is treated as a digital signal and its value is transmitted according to the rules for a digital input.

### 2.3.5 Low Battery Voltage Alarm

If the voltage of the internal battery supply falls below 2.9 volts, the internal battery voltage alarm will turn on.

The Low Battery Voltage Alarm is treated as a digital signal and its value is transmitted according to the rules for a digital input.

When the a low battery condition occurs, the low battery status will need to be reset - refer to section 5 of this manual.

### 2.3.6 Communications Failure

The 505U cannot provide an indication that its transmitted messages have not been received successfully.

This indication is however available at the **receiving 105U** by using the 105U Output Reset on Comms Fail function. To use this function, map an input that is not being used on the 505U to a spare output on the 105U. The unused input can be an internal input such as the Low Battery status or Setpoint status, or even the analogue input as this can also be mapped to a digital output. Configure the 505U so that the digital output at the 105U is normally on - you can configure an input to output mapping to be inverted or direct.

If you configure a reset time to the 105U output, then this output will turn off if it has not received an update message from the 505U within that time. The 105U output is effectively a "Communications OK" output - on when communications are OK, and off during communications failure. Note that the maximum output reset time at the 105U is 32 minutes, so the update time for the 505U input must be less than this. It is generally a good idea to set the update time to less than half of the reset time. Then, the 105U must fail to receive two consecutive update messages - it is possible to miss one update message because of random noise, but two consecutive failures means that there is a system failure. For example, if you wish to have a failure alarm within 10 minutes of a system failure, set the output reset time at the 105U to 10 minutes and the update time at the 505U to 4.5 minutes.

## 2.4 How to Design a Remote Monitoring System

### 2.4.1 Achieving reliable radio transmission

A system can theoretically have an unlimited number of 505U modules, but in practice, the number is limited by the amount of radio traffic on one frequency in the system. When a radio channel becomes unreliable because of radio traffic, then a second radio channel must be used to increase the size of the system. This limit is not a function of the number of modules, but the number of radio messages.

A system comprises 505U and 105U modules - each can transmit input signals. The 105U can "hear" other radio messages, and will hold off transmitting a message until the radio channel is clear. The 505U module cannot, and there is a possibility that an individual transmission will clash with another transmission, and both transmissions will be corrupted. This possibility increases as the density of transmissions increases. Configuring the re-transmit feature (transmission of each message several times) will increase the chance of each message being received successfully, but will increase the overall density of radio traffic.

For large systems, a compromise is required between the number of re-transmissions, and the update times for each input. High priority inputs should have shorter update times than lower priority inputs.

The peak transmission density should be calculated for large systems. These values are calculated by determining the number of transmissions from inputs changing value and the number of update transmissions per hour.

The probability of success for an individual message depends on the transmission density and the number of re-transmissions for each message. This is shown in the following graph:

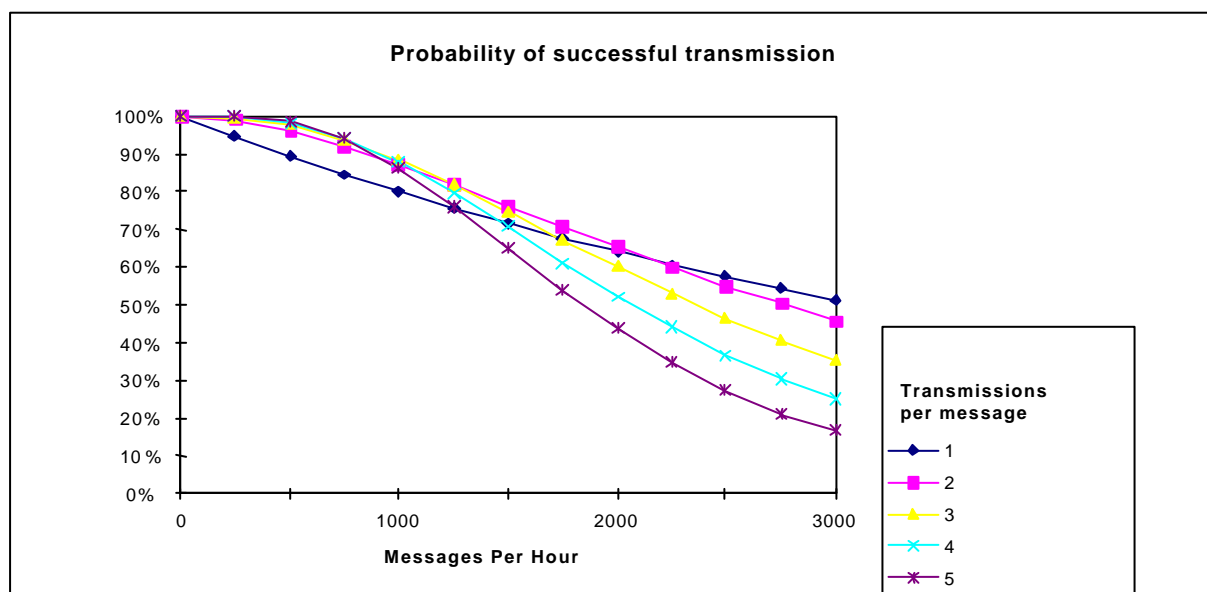

This assumes that the radio path is reliable and that there is no other radio users on this radio channel. If intermediate repeaters are used, then each repeated message should be counted as another message.

We suggest that you use two transmissions per message - with a higher number for a small number of high priority inputs.

In addition to the above comments, you need to consider the affect of re-transmissions on other messages being transmitted from the same 505U module. Once a 505U starts transmitting a message, all transmissions for this message must be complete before another transmission can start. The time between retransmissions of the same message is a random time between 0.5 and 4 seconds. For example, if a module is configured to transmit each message 5 times, then each message will take up to 16 seconds. Another message cannot be transmitted until the previous message has finished. In the above example, the maximum number of messages which can be transmitted reliably is approx 4 per minute. If more messages are required, then a lower number of re-transmissions should be selected.

#### **2.4.2 How far will the radio transmit?**

The 505U will operate reliably over large distances. The distance that may be reliably achieved will vary with each application and is dependent on the following factors:

- Type and location of antennas (the higher an antenna is, the further it will transmit)
- Amount of radio interference from other transmitters or radio “noise”
- Obstructions such as buildings, hills or trees in the radio path
- Maximum radio transmitter power allowed in the country

The transmitter power level of each 505U is set in the factory to the maximum power allowed in the country of sale. The maximum output power of the 505U is 500mW, however only 250mW can be achieved using internal batteries. If internal battery supply is used, then the 250mW power can be increased to 500mW by using a 3dB gain antenna such as a 3 element Yagi or a 3dB collinear antenna - refer to the section 3.2 Antenna Installation.

The following distances are expected "line-of-sight" distances which can be expected to be achieved with reliable operation. This range can be increased by higher gain antennas, or higher antennas, and is decreased by radio interference and obstructions.

<b>Power Level mW</b>	<b>Distance km</b>
500	10
250	7
100	5
10	2

## 2.5 Calculating Power Consumption

The following information may be used for calculating power consumption.

		Voltage Supply $\Delta$ volts (6 – 12)	BU-5-1 Battery Pack
		mA	mAHr
Quiescent	constant regardless of voltage	0.14	3.4 per day
Each radio transmission	Transmission time 42msec	700	0.005
	6V 12V	300	per transmission
Analogue input measurement (per measurement)	Externally powered transducer - constant regardless of voltage	10	Not applicable
	Loop Powered Transducer - 12 mA average	355 / $\Delta$	0.012 x w-time per measurement
	Loop Powered Transducer - 20 mA average	576 / $\Delta$	0.020 x w-time per measurement
Pulse Input	0 - 10 Hz (Slow Pulse Inputs)	0.0025 x f	0.06 x f per day
	> 10Hz (Fast Pulsed Inputs)	0.2	4.8 per day

w-time = warm up time in seconds      f = average pulse frequency in Hz       $\Delta$  = supply volts

The overall current or energy requirements may be calculated by using the above figures.

Total energy per day = Quiescent  
 + Pulse input (if used)  
 + Analogue input per measurement x number of measurements per day  
 + Radio transmission x number of radio transmissions per day

There is no additional power required for digital inputs.

Where the BU-5-1 battery pack is used, these figures can be used to determine the expected battery life. A BU-5-1 with new batteries has a capacity of 1.7 amhours (1700 mAHr). If two BU-5-1's are connected, the second pack provides an additional 1200 mAHr.

### Example:-

An application has one digital input, one pulse input and one analogue input. It is powered by a single BU-5-1 battery pack. Each radio message is configured to transmit two times.

The total power consumed = power for transmissions + power for analogue loop supply + pulse input + quiescent

### Power for radio transmissions:-

The configuration parameters, and estimated activity data, for each input are:

**Digital input**      Update time, off state      1 day  
                                  Update time, on state      15 minutes  
                                  Input is expected to be on twice per year for 4 hours

No. of change messages per year = 2 (twice per year) \* 2 (on to off and off to on)  
 = 4

No. of "off" update messages per year = 364 (approximately)

No. of "on" update messages per year = 2 (twice per year) \* 16 (4 hours @ 15 min update)  
 = 32

Total messages for digital input = 4 + 364 + 32 = 400

**Pulse input** Update time 1 day Sensitivity 50

Average pulse rate is 1 pulse per hour, with peak rate of 20 per hour, for 10 hours, three times per year.

No. of change messages (normal rate) = 0 (time for 50 pulses is more than the update time)

No. of change messages (peak rate) = 3 (three per year) \* 200 (20 per hr for 10 hrs) / 50  
 = 12

No. of update messages per year = 363 (approx)

Total messages for pulse input = 12 + 363 = 375

**Analogue input** Sample time 1 hour Warm-up time 5 secs  
 Sensitivity 3% Update time 1 day

Average changes of >3% is twice per day

No. of change messages per year = 2 (twice per day) \* 365  
 = 730

No. of update messages per year = 0 (always be a change message each 1 day)

Total messages for analogue input = 730

Total input messages per year = 400 + 375 + 730 = 1505

**Power consumed in transmissions** = 0.005 \* 1505 \* 2 (2 transmissions per message)  
 = 15 mAHr per year

**Power for analogue loop supply** (assume average loop current is 12mA)

No. of analogue measurements per year = 365 days \* 24 hours \* 1(sample time)  
 = 8,760

Power for analogue loop supply = 0.012 (from above table) \* 5 (warm-up time) \* 8,760  
 = 526 mAHr per year

**Power for pulse input**

Average pulse rate is 1 pulse per hour (0.0003Hz), so power required = 0.06 x 0.0003 per day  
 = zero

**Quiescent power**

Power for quiescent current	=	3.4 per day * 365	
	=	1241 mAHr per year	
<b>Total power consumption per year</b>	=	<i>15 + 526 + 0 + 1241</i>	
	=	1782 mAHr	
Expected battery life is	=	1700/1782	= 0.95 year

Note that battery life is shortened during configuration or diagnostics. When the serial cable is connected to the 505U, the module does not revert to sleep mode and the power consumption is considerably increased. These periods should be minimised if you are using a battery pack.

## 3 HARDWARE INSTALLATION

**WARNING!** 110/220/240V mains power must NOT be connected to any input terminal of the 505U module!

The 505U module is housed in a weatherproof enclosure with external power and input signals connected via a weatherproof connector at the bottom of the module.

Wires of up to 0.75 sqmm may be connected by soldering to the female connector supplied with the unit. The antenna/coaxial cable connector is a BNC at the top of the module. Care should be taken to ensure that this connection remains weatherproof, as the ingress of water will decrease radio performance. If necessary, wrap the connection with weatherproofing tape.

**Before installing a new system**, it is preferable to bench test the complete system as configuration problems are easier to recognise when the system units are close together.

Following installation, poor communications can be caused by:

- Incorrectly installed antennas
- Radio interference on the same channel
- Obstructions in the radio path
- Radio path too long

If the radio path is a problem, higher performance antennas or a higher mounting point for the antenna may help. Alternately, use a 105U module as a repeater.

The foldout sheet *505U Installation Guide* is included with the product, with more detailed information in the following sections:

### 3.1 How to mount the 505U

The 505U module is housed in an IP66 weatherproof aluminium enclosure. To mount the 505U, remove the four screws in the top plate, and carefully remove the cover. The two mounting holes should now be visible.

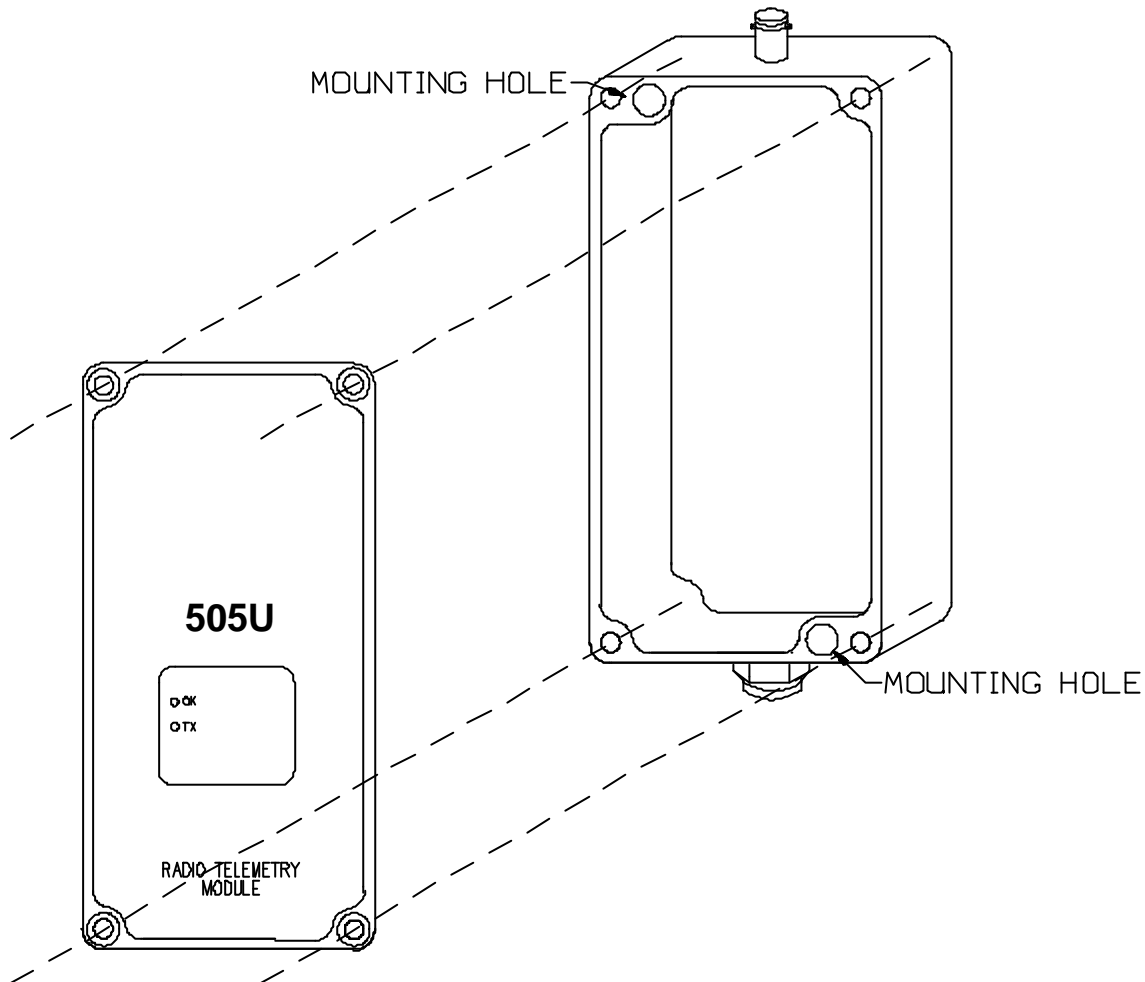

It is important to effectively earth the unit to help prevent radio noise and static electricity damage. The preferred method is to earth the module using the mounting screws to connect to an earthed surface. If this is not possible, use an earth lug in the mounting screw connection and secure the other end of the wire to a good earth.

### 3.2 Antenna Installation

The 505U module will operate reliably over large distances. The distance that may be reliably achieved will vary with each application - depending on the type and location of antennas, the degree of radio interference, and obstructions (such as hills or trees) to the radio path. Where it is

not possible to achieve reliable communications, a 105U module may be used to receive the message and re-transmit it. This module is referred to as a repeater. This module may also have input/output (I/O) signals connected to it and form part of the I/O network.

An antenna must be connected to each 505U module using the BNC female connector that protrudes through the top of the enclosure.

To achieve the maximum transmission distance, the antennas should be raised above intermediate obstructions so the radio path is true “line of sight”. Because of the curvature of the earth, each antenna will need to be elevated at least 5 metres above ground for paths greater than 5 km (3 miles). The modules will operate reliably with some obstruction of the radio path, however the reliable radio range is decreased. Obstructions that are close to either antenna will have more of a blocking effect than obstructions in the middle of the radio path.

Small whip antennas may be connected directly to the 505U module. Other antennas may be connected to the module via 50 ohm coaxial cable (eg RG58 or RG213) terminated with a male BNC connector. Connections between the antenna and coaxial cable should be carefully taped to prevent ingress of moisture.

Moisture ingress in the coaxial cable is a common cause for problems with radio systems, as it greatly increases the radio losses. We recommend that the connection be taped, firstly with a layer of PVC Tape, then with a vulcanising tape such as “3M 23 tape”, and finally with another layer of PVC UV Stabilised insulating tape. The first layer of tape allows the joint to be easily inspected when trouble shooting as the vulcanising seal can be easily removed.

The higher the antenna is mounted, the greater the transmission range will be, however as the length of coaxial cable increases so do cable losses. There are several types of antennas suitable for use on unlicensed frequency channels. It is important that the antenna is chosen carefully to avoid contravening the maximum power limit on the unlicensed channel - if in doubt refer to an authorised service provider.

Connections between the antenna and coaxial cable should be carefully taped to prevent ingress of moisture. Moisture in the coaxial cable is a common cause for problems with radio systems, as it greatly increases the radio losses. We recommend that the connection be taped with a vulcanising tape such as “3M 23 tape”, with a secondary layer of PVC insulating tape.

Where antennas are mounted on elevated masts, the masts should be effectively earthed to avoid lightning surges. Surge suppression devices are recommended if lightning surge problems are likely in the installation area. If the antenna is not already shielded from lightning strike by an adjacent earthed structure, a lightning rod may be installed above the antenna to provide shielding.

### **Whip antenna**

A whip antenna is a small rubber coated antenna designed to connect directly to the 505U BNC connector. It is suitable for applications up to 25% of the maximum distance for the power level. Although the antenna has a negative gain (the power transmitted by the antenna is less than that produced by the module), it is easy to use and low cost.

## Dipole antenna.

A unity gain dipole is the normal antenna for use on unlicensed channels. As it does not provide any gain, then the power transmitted from the antenna will be the same as the power out of the module. Dipole antennas are available with a BNC connector for direct mounting on the 505U module, or with coaxial cable for mounting away from the module. Dipole antennas should be mounted vertically, at least 1 metre away from a wall or mast.

For **marginal** radio paths, the following lengths are the recommended **maximum** for the coaxial cable to the dipole antenna: RG58 - 10 metres      RG213 - 25 metres. Note that this applies to marginal paths only - if the radio path has a strong radio signal, then longer lengths of cable (and hence more cable loss) can be tolerated. If more than 25 metres of cable is required for a marginal path installation, then a low loss cable such as RG9913, or a higher gain antenna should be used.

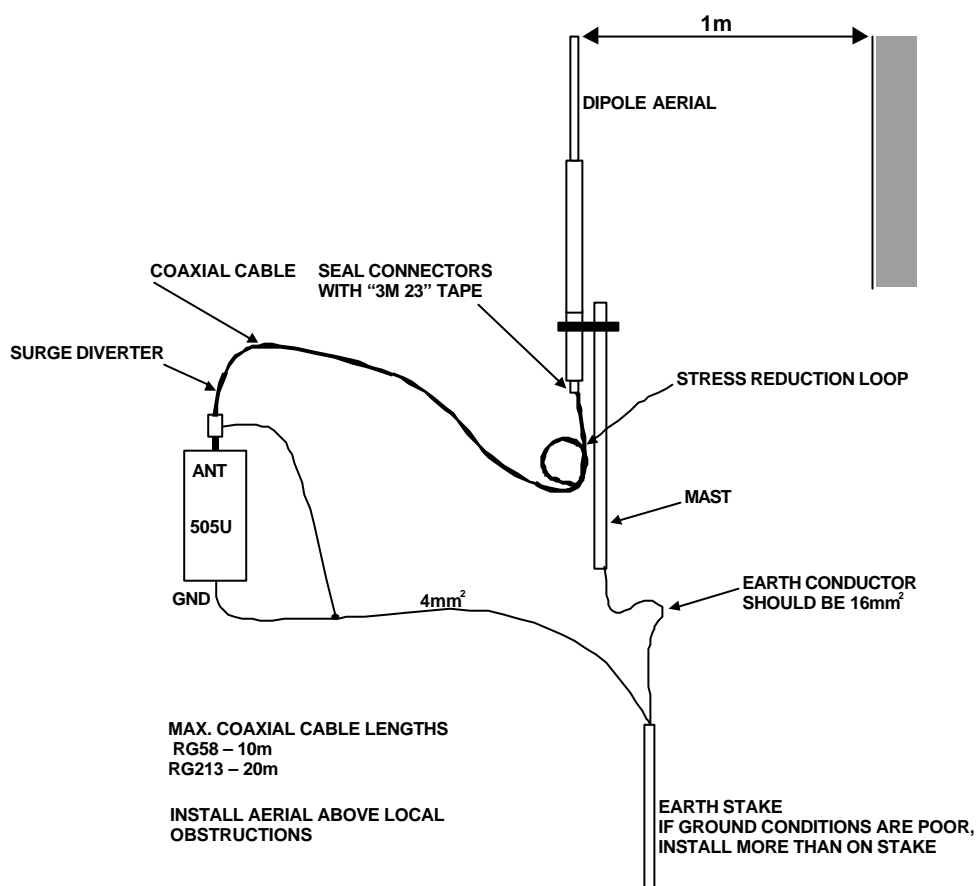

The 505U can produce 500mW of radio power when an external 12VDC supply is used, but only 250mW of power with internal batteries. This power may be boosted to 500mW by using a higher gain antenna (3dB) such as a 3 element Yagi or a 3dB collinear antenna. These higher gain antennas may also be used to compensate for coaxial cable loss. The losses are 3dB for every 10m of RG58 and 1.5dB for every 10m of RG213. If 10m of RG58 cable is used on a marginal radio path, then a higher gain antenna may be used to cancel the losses in the cable and boost the transmitted power back to the maximum level. Note that you can accumulate gains - if you need 3dB to boost 250mW to 500mW and another 3dB to compensate for coaxial cable, then you can install a 6dB gain antenna and be sure of transmitting the maximum power allowed.

### **Three element YAGI antenna.**

YAGI antennas are directional. That is, they have positive gain to the front of the antenna, but negative gain in other directions. Hence YAGI antennas should be installed with the central beam horizontal and must be pointed in the direction of transmission to benefit from the gain of the antenna. The high gain spread of a 3 element Yagi is approx 30°, so great accuracy is not required. Also note that YAGI antennas normally have a drain hole on the folded element - the drain hole should be located on the bottom of the installed antenna.

The YAGI antennas may be installed with the elements in a vertical plane (vertically polarised) or in a horizontal plane (horizontally polarised). For a two station installation, with both modules using YAGI antennas, horizontal polarisation is recommended. If there are more than two 505U modules transmitting to a common 105U module, then the YAGI antennas should have vertical polarisation, and the 105U module should have a dipole or collinear (non-directional) antenna.

### 3.3 Connection Plug

External power and input signals are connected using a 7 pin weatherproof plug, provided with the module. The plug needs to be assembled as per the following diagram.

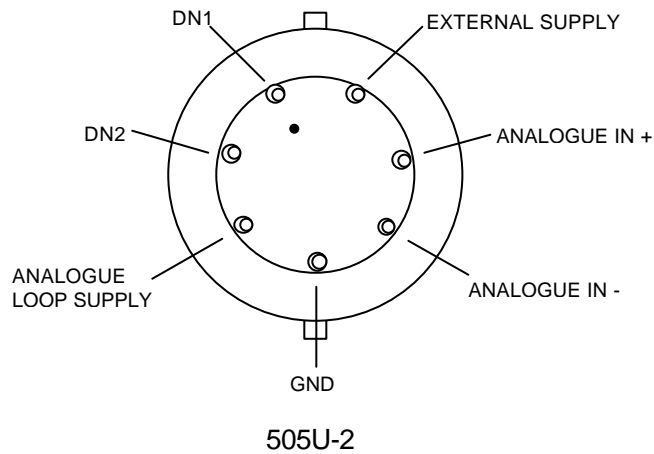
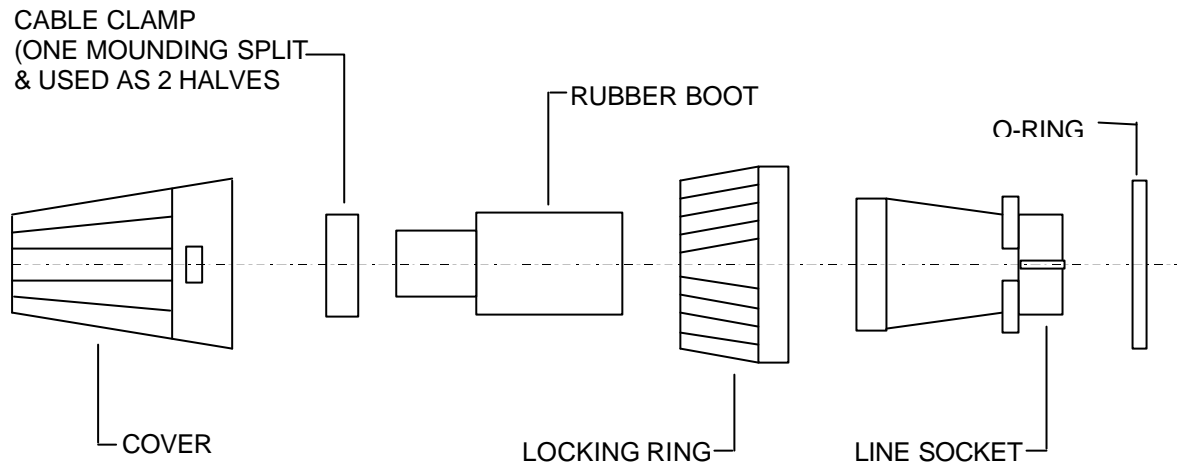

505U-2

**NOTE: VIEW FROM SOLDER CONNECTION SIDE OF PLUG**

### 3.3.1 PL1-K Plug Lead

The PL1-K plug lead assembly is a 1 metre cable pre-terminated to the connector plug. The connector connections are:

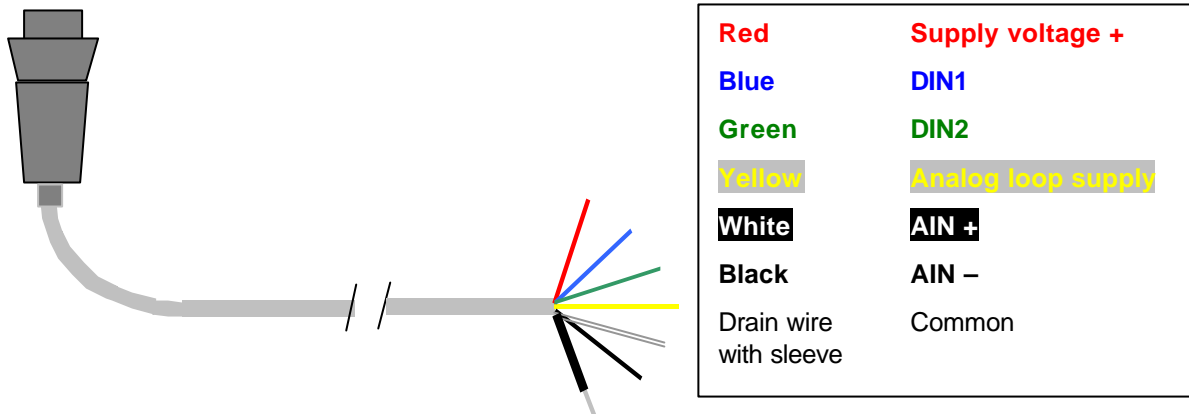

## Power Supply Installation

### 3.4.1 External Power

The 505U module will accept an external supply of 11.5 - 15.0 volts DC. An external supply with a battery and battery charger is suitable. Negatively grounded or floating supplies are acceptable, however **positively grounded supplies must not be connected**. The 505U connects the negative supply (COMMON) to “ground”. Connect the external supply as per the following diagram.

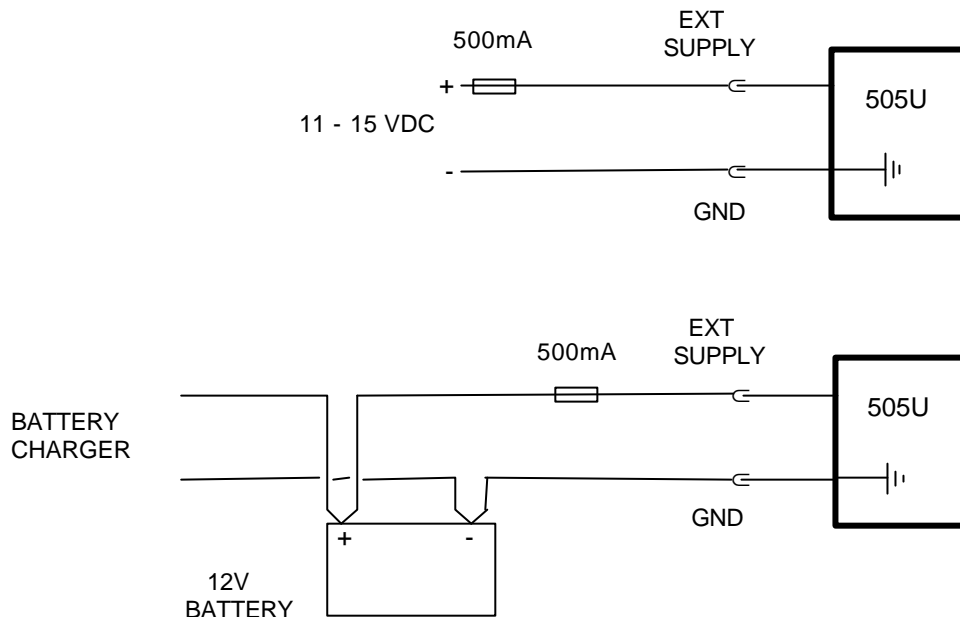

### 3.4.2 Internal Battery Power

To install internal batteries, remove the module cover by unscrewing the four screws on the front panel.

Two battery options may be installed:

- 3 x lithium AA, 1.5V batteries, e.g. Energiser L91
- 3 x alkaline AA, 1.5V batteries, type Duracell MN1500B4, Eveready E91, or equivalent

Lithium batteries would normally be used where the module is likely to experience temperature extremes, Lithium batteries can operate down to  $-40^{\circ}\text{C}$

An optional external battery pack Model BU-5-1, using 6 x AA Batteries of either the above types (can be used with internal batteries installed or not)

**Caution:** Never mix two types of battery (Lithium & Alkaline), always replace a full set of batteries.

Configuration of the module will **not be lost** when batteries are removed, so no special procedure is required when replacing batteries.

### 3.4.3 Battery Pack BU-5-1

The BU-5-1 can be installed underneath the 505U or beside it. The BU-5-1 uses the same type of enclosure as the 505U and is mounted in the same way. The BU-5-1 has a “cable tail” which plugs into the 505U. The input wiring is then connected to a socket on the BU-5-1.

The lid of the BU-5-1 can be rotated to suit installation.

A second BU-5-1 can be connected to the first in a similar manner. The input wiring for the 505U is then connected to the socket on the second BU-5-1.

*All plugs and connectors should be waterproofed with waterproofing tape.*

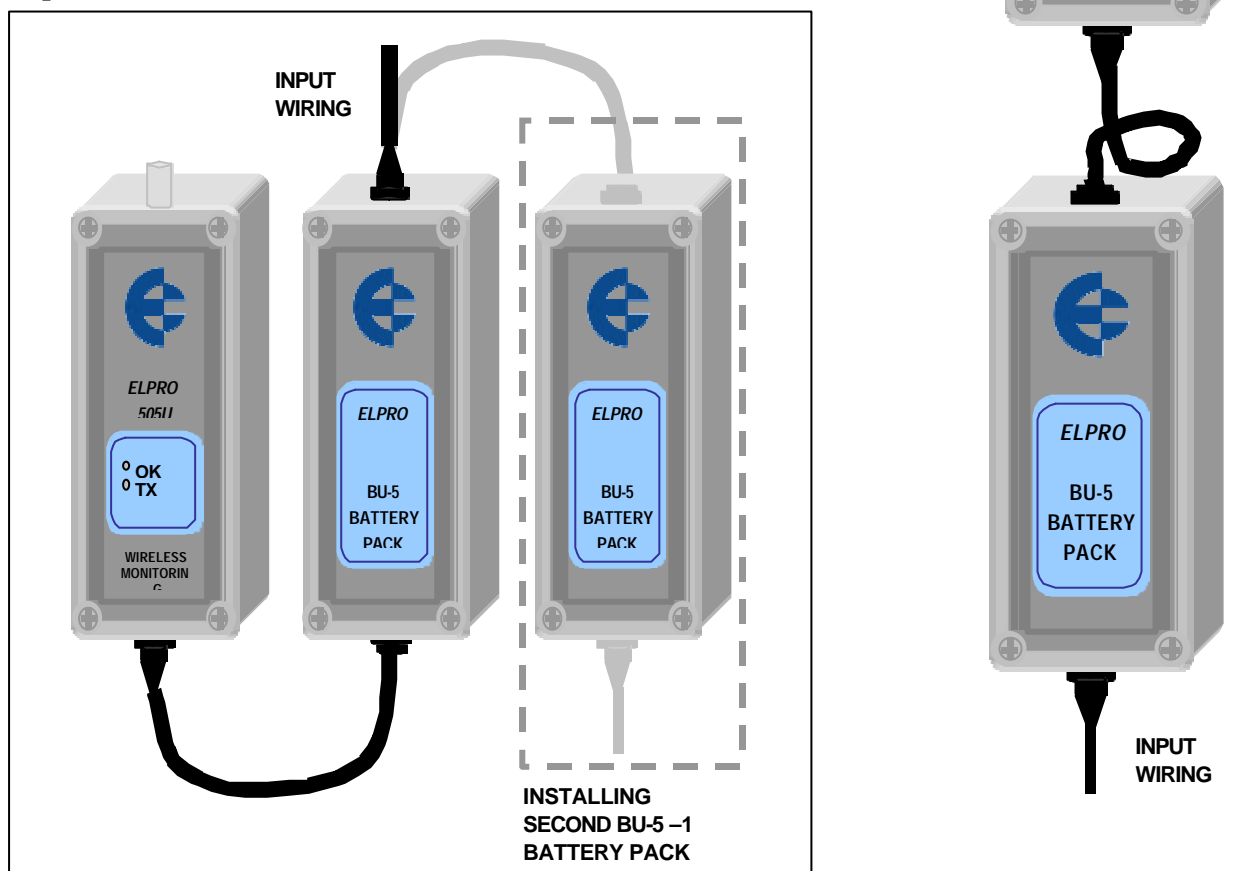

**Check the label on the back of the BU-5-1 to make sure that it has been factory-set to 4.5Volts (model BU-5-1).**

The BU-5-1 takes two types of batteries, Alkaline or Lithium. Alkaline Batteries have a temperature range of  $-20^{\circ}\text{C}$  to  $+54^{\circ}\text{C}$  ( $-4^{\circ}\text{F}$  to  $130^{\circ}\text{F}$ ) while Lithium have a temperature range of  $-40^{\circ}\text{C}$  to  $+60^{\circ}\text{C}$  ( $-40^{\circ}\text{F}$  to  $140^{\circ}\text{F}$ )

Typical alkaline batteries used are Eveready E91, Duracell MX1500 etc while Lithium Batteries are the Eveready L91

The BU-5-1 takes six AA batteries. Do not use rechargeable batteries in the BU-5-1 as their self discharge life is short. The temperature rating of the BU-5-1 depends on the battery type

Operation of the 505U will stop during battery change, however configuration of the module will **not be lost** when batteries are removed, so no special procedure is required when changing batteries of the same type.

Batteries should be inserted as per the drawing - with the BU-5-1 aligned such that the cable comes out of the top of the module.

The BU-5-1 can be mounted in any direction. The enclosure lid can be rotated.

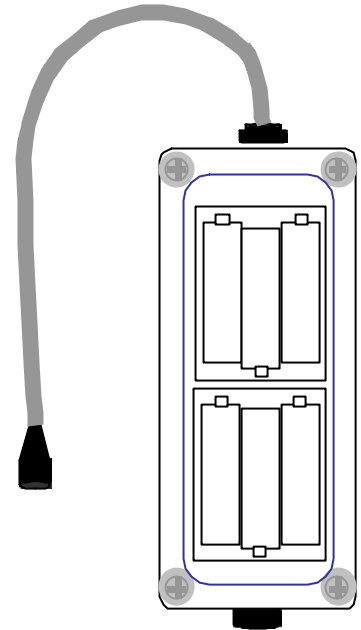

### 3.5 Input Signal Connections

#### 3.5.1 Digital/Pulse Inputs

Digital and pulse inputs share the same input channel. Each input is connected between the DIN connector and COMMON. Inputs can be voltage-free contacts, NPN transistor switches, or a voltage signal (ON < 1 volt DC, OFF > 2 volts DC).

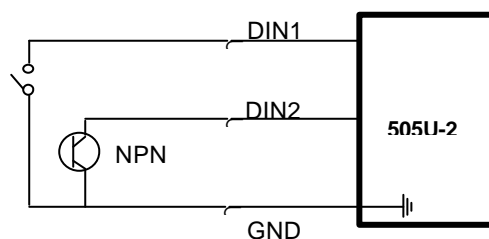

**Inputs can be voltage free contact or open-collector transistor**

Inputs do not have any surge protection. If the sensor or switch is mounted a long way from the 505U module, external isolation such as a relay may be required for surge protection.

### Shaft Encoder Connections

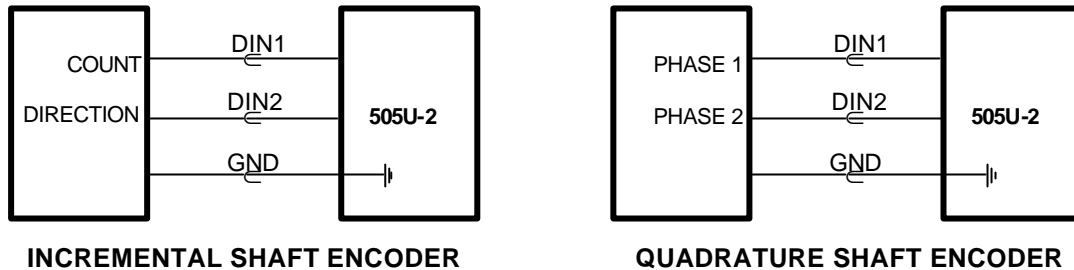

### 3.5.2 Analogue input

The analogue input has a positive and a negative terminal, and may be placed at any point in the current loop, as long as neither input rises more than 15V above COMMON or ground. A 12 VDC 20mA supply is provided for powering analogue loops (both 505U-E and 505U-B modules). The analogue loop may be powered from the internal supply or may be externally powered.

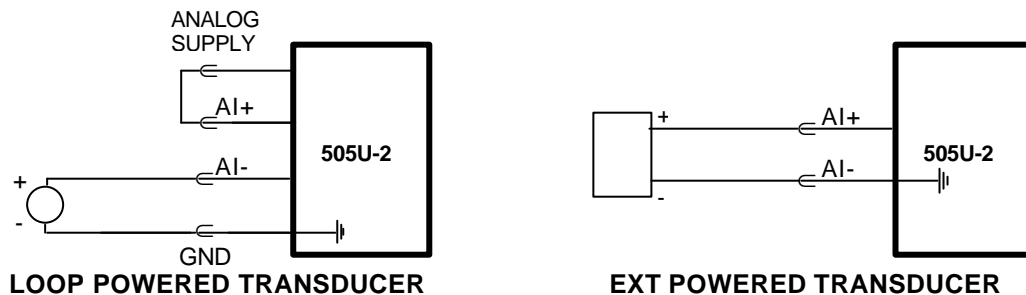

Loop powered transducers must be suitable for low voltage operation. Loop voltage available for the transducer is 8.5V for 505U-B modules and 1.5V less than the power supply voltage for 505U-E modules.

Shielded cable is recommended for analogue input loops to minimise induced noise and radio frequency interference (RFI). The shield of the cable must be connected to earth at one end of the cable only. Each input has a loop resistance of 150Ω and zener diode protection against overvoltage and reverse voltage. Additional surge protection is recommended in high electrical noise environments, or if the analogue signal cable runs for a long distance underground before connecting to the 505U module.

### 3.5.3 RS232 serial port

An RS232 port is provided for connection of a PC for configuration and diagnostics. To access the serial port DB9 connector, remove the front cover from the module by unscrewing the four screws in the front panel. The serial port is a 9 pin DB9 male and provides for connection to a terminal or

to a PC for configuration, field testing and for factory testing. Communication is via standard RS-232 signals. The 505U is configured as DCE equipment with the pinout detailed below.

Pin	Name	Dirn	Function
1	-	-	Not Used.
2	RD	Out	Receive Data - Serial Data Output (High = 0, Low = 1)
3	TD	In	Transmit Data - Serial Data Input (High = 0, Low = 1)
4	DTR	In	Data Terminal Ready - used by 505U as a "wake-up" signal
5	SG	-	Signal Ground
6	-	-	Not Used.
7	-	-	Not Used.
8	-	-	Not Used.
9	-	-	Not Used.

**The DTR signal must be connected to the 505U** to enable communications and “wake up” the microprocessor. This means that the DTR wire must be connected - the PC does not need to control DTR. When communications is established, the green LED will light continuously.

The serial port communicates at a baud rate of **4800** baud, 8 bits, no parity, one stop bit.

An example cable drawing for connection to a personal computer is detailed below:

E505 DB9 (M) Connector

Computer DB9 (F) Connector

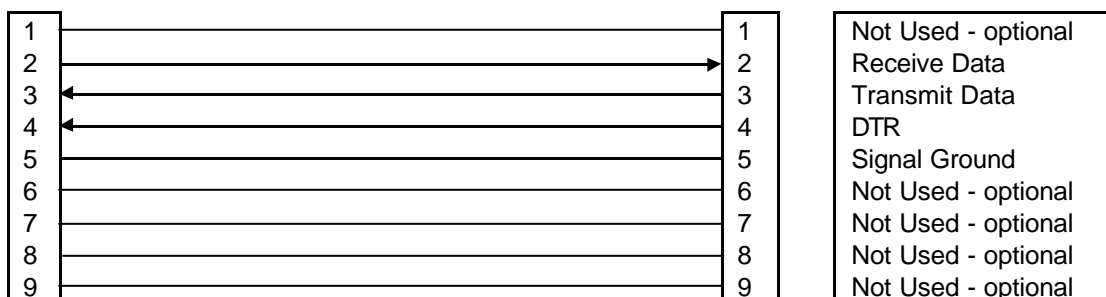

## 4 CONFIGURATION

The 505U module is configured by creating a configuration file on a PC and downloading to the 505U via the RS232 serial port. You will require the configuration software, and a serial cable - refer to the previous section.

The configuration software is supplied as "free-ware" on the Product Catalog CD supplied with each order. The configuration software for the 505U is the same as the software for the 105U. Please read section 4.3 of the 105U User Manual before proceeding further.

Setup the project name and system address as per the 105U manual. Enter the "units" as per the manual. Select "505-2" as the unit type for 505U modules.

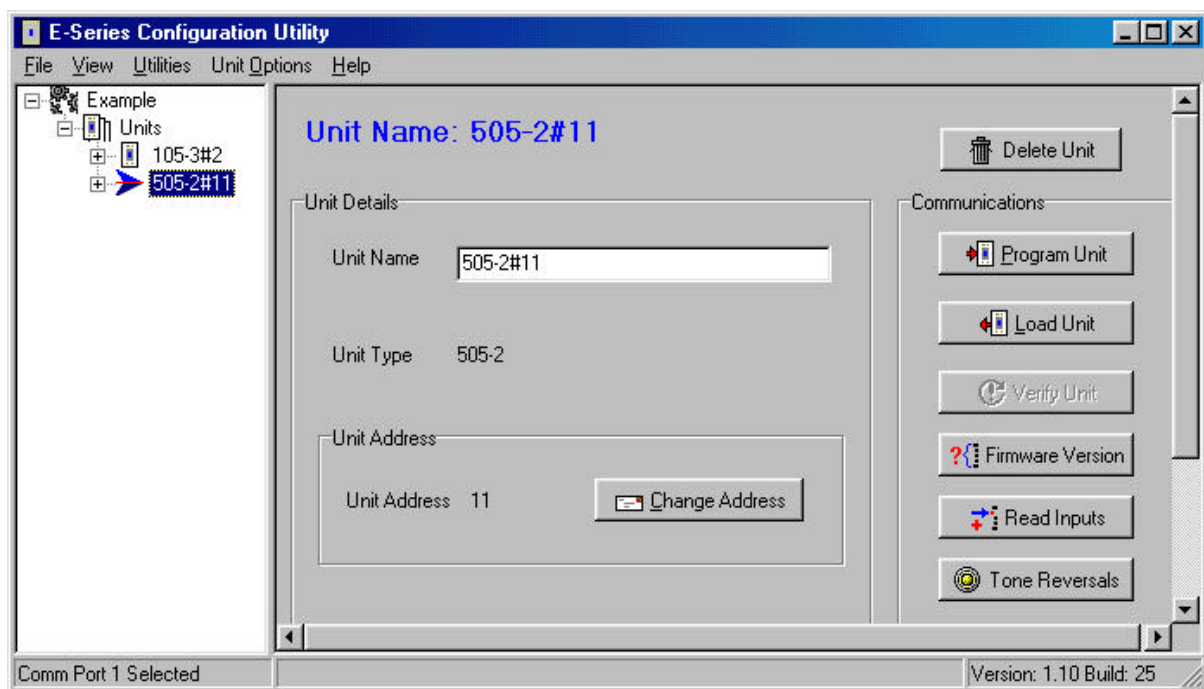

Each 505U has a unit address and a secondary address. Up to eight 505U modules can use the same system address. If you enter the same unit address for more than one 505U, the configuration software will automatically increase the secondary address. The default description of a 505U module is 505-2#10\_1 where 10 is the unit address and 1 is the secondary address. If a unit address of 10 is chosen for another 505U module, it will have a default description of 505-2#10\_2. For small systems, select a unique unit address for each 505U module.

### 4.1 I/O Mapping

Enter I/O mappings as per the 105U manual.

In the following example, a digital input at a 505U is mapped to DO1 of 105U#13. The analogue inout of the 505U is mapped to AO2 of the same module.

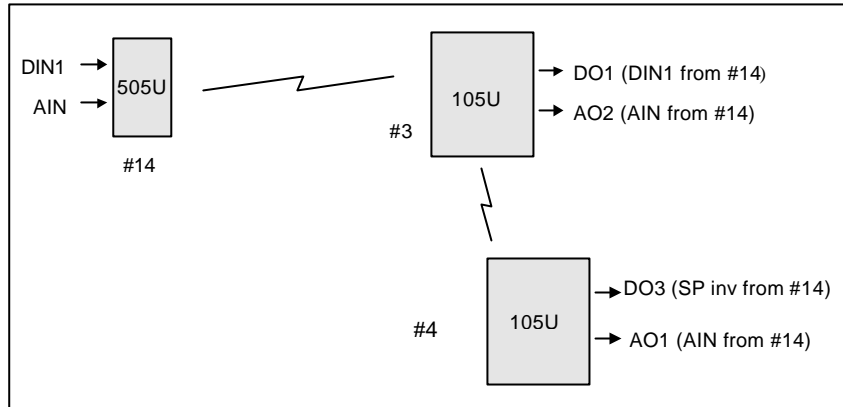

The setpoint status of the 505U is mapped (inverted) to DO3 of 105U#14, using 105U#13 as a repeater. The 505U AI is also mapped to AO1 of this module. That is, the AI is mapped twice.

The mapping configuration for the 505U would be :

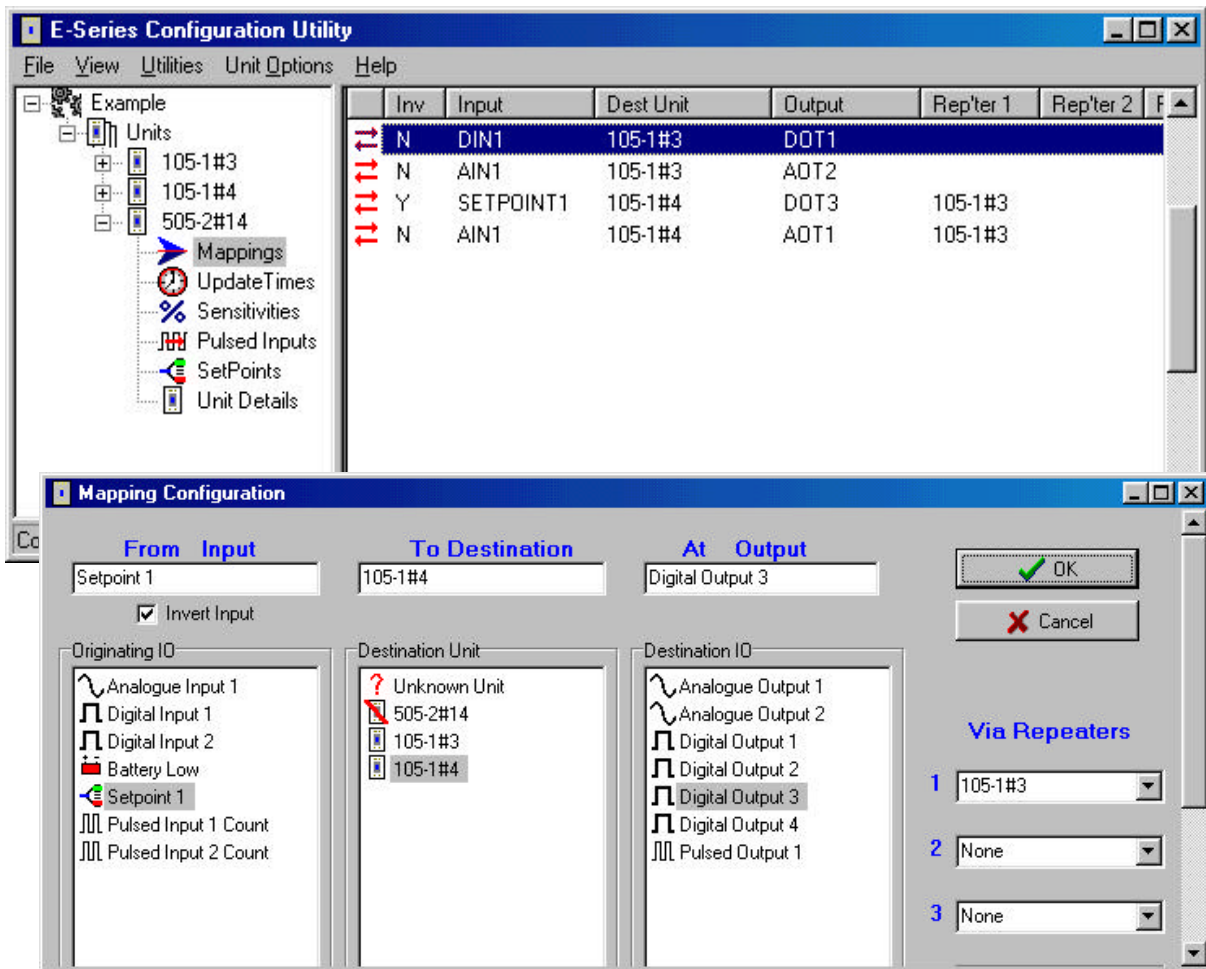

### 4.2 Update Transmission Times

Each input signal has an update time. If a change has not occurred for this input within this time, then a transmission is set for this input after the update time has expired. Each input signal has its own timer - when a transmission occurs for this input (either a change transmission or an update transmission) the timer is reset to zero. If the timer reaches the Update Time value, then a update transmission occurs.

Digital inputs (both external inputs and internal) have a separate update time for their "off" state and "on" state. This allows the input to be reported differently depending on its state. If the digital input is an

alarm, then a user may wish the input to be updated more frequently when in the alarm state than when not in the alarm state. The analogue input and pulsed inputs only have one update time value.

Valid values are 10 seconds to 120 hours. If less than 10 seconds is entered, the value will default to 10 seconds. If zero is entered, then there will be no update transmissions for this input.

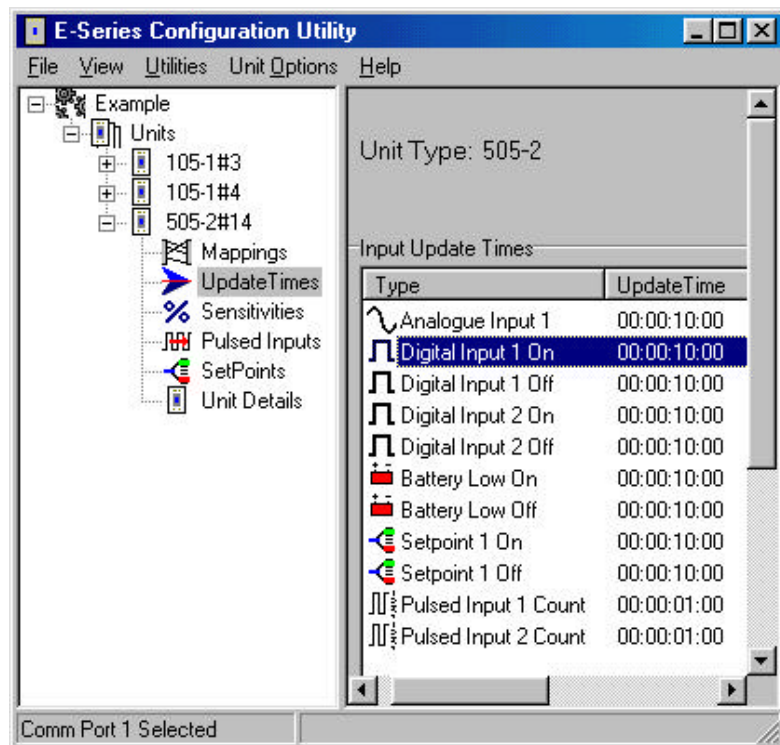

### 4.3 Digital Inputs

Apart from update times, the only configurable parameter for digital inputs is the paralysis time. This parameter can be changed by selecting the Unit details option.

If a value of zero is entered, then there is no paralysis time.

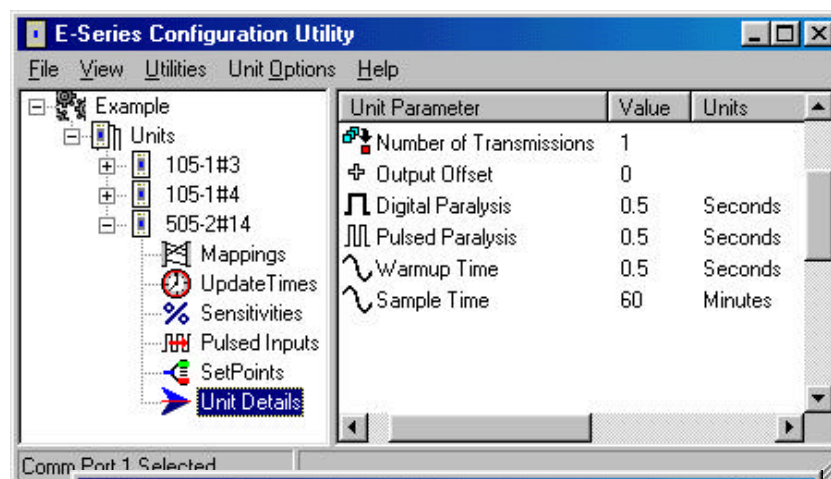

### 4.4 Analogue Input

There are three parameters which may be adjusted for the analogue input.

The **change sensitivity** is the amount of change since the last

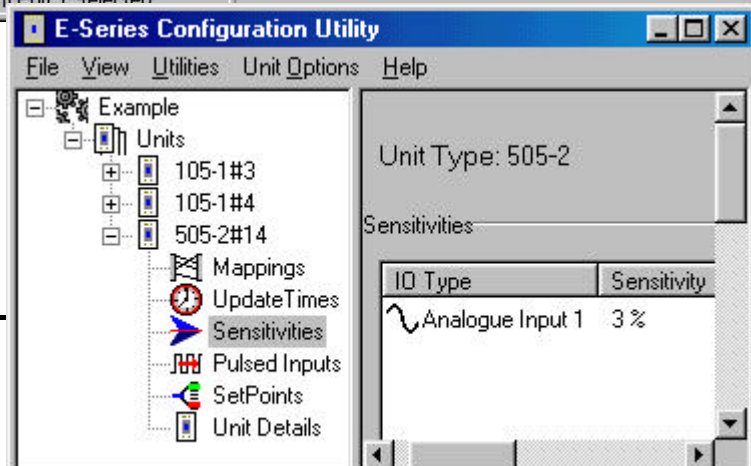

transmission which will trigger another transmission for this input. For example, if the last transmitted value of the input was 55.0%, and the sensitivity is 1.2%, then another transmission will occur if the measured input value is less than 53.8% or more than 56.2%. If change messages are not required, then a sensitivity of 100% should be selected.

Each 1% corresponds to 0.2mA of signal. The sensitivity should be set to be greater than the natural "signal noise" of the analogue input. For example, if there is a signal oscillation of 1% on the input, then a sensitivity of less than 1% will result in continuous change transmissions which could overload the radio channel.

The **sample time** is the time period for each analogue input measurement. Between measurements, the 505U will operate in "sleep" mode. When the sample time has expired, the 505U will turn on the analogue loop power supply. After a further time, called the **warmup time**, the 505U will make a measurement of the input. The warmup time allows the transducer to stabilise and become accurate after the loop supply is turned on.

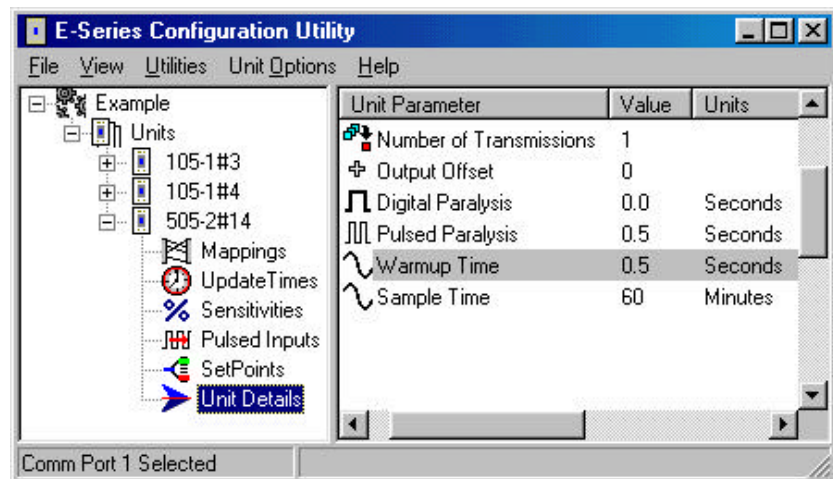

The sample time may be entered in minutes, between 1 and 30 000 minutes. If a zero value is entered, then the loop power supply will be always on. The warmup time may be entered in seconds between 1 and 127 seconds. If a zero value is entered, then an analogue measurement will be made as soon as the loop supply is turned on. If both the sample time and warmup time are set to zero, then an analogue measurement will be taken on every 505U cycle (every 0.5 sec).

## 4.5 Analog Setpoints

A high setpoint value and a low setpoint value may be entered. The internal setpoint status is determined by these values in comparison to the analogue input value. If the analogue input is less than the low setpoint, then the setpoint status is "on". If the analogue input is more than the high setpoint, then the setpoint status is "off". When the input is between the low and high setpoints, then the setpoint status remains unchanged.

The setpoint values may be set between 0 and 100% corresponding to 0mA and 20mA. The low setpoint may be set to the same value as the high setpoint, however the low setpoint should not be set to a higher value than the high setpoint.

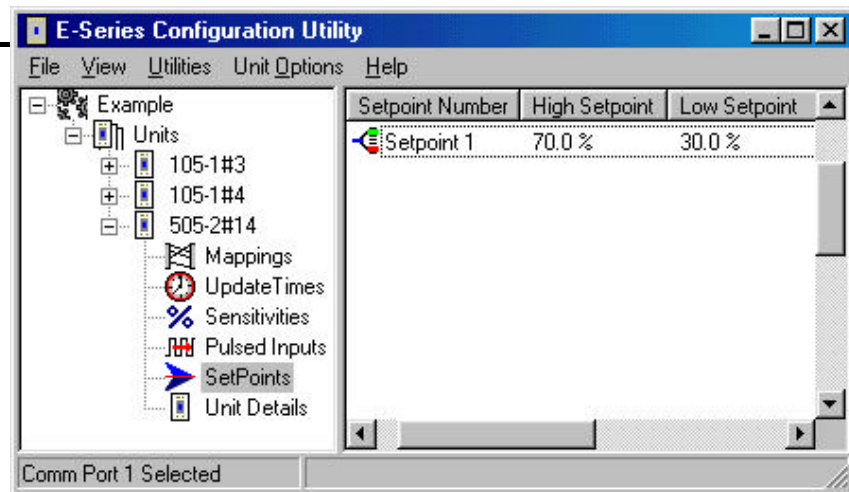

## 4.6 Pulse Inputs

There are several configurable parameters for pulse inputs. The debounce value can be adjusted from the Unit Details selection, as per Digital Inputs.

If either pulse input has an input rate of more than 10Hz, then the Fast Pulse Input option should be selected from the Pulsed Inputs selection.

If the pulse inputs are connected to a shaft encoder (incremental or quadrature types), then the Shaft Encoder Inputs option should be selected.

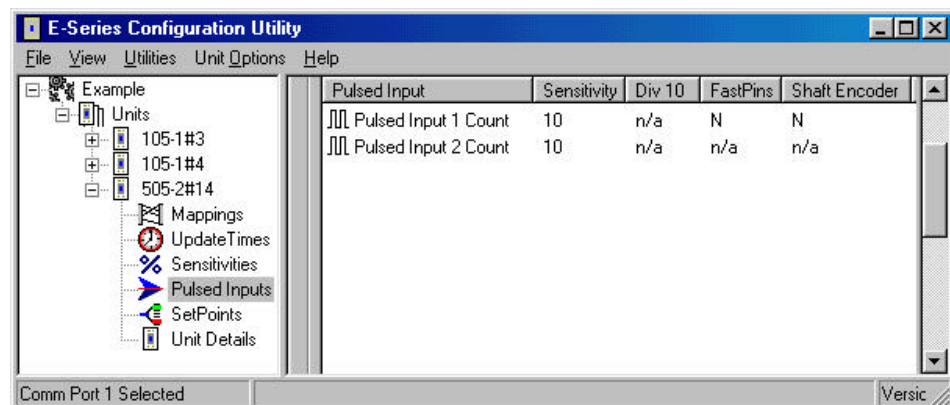

The pulse inputs

also have a Sensitivity value. The pulse input sensitivity is the number of pulse increments since the last transmission to trigger another transmission. For example, if the pulse count at the last transmission for a pulse input was 1000, and the sensitivity value is 10, then another transmission will occur when the pulse count reaches 1010 (provided there has not been an update transmission during this period). The sensitivity values can be between 1 and 32000.

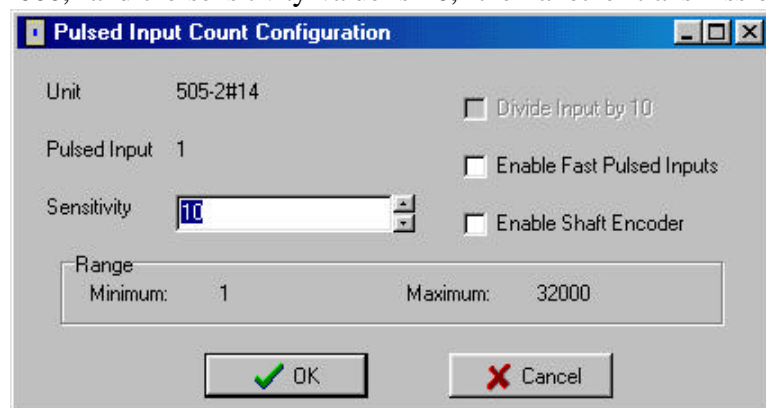

## 4.7 Number of Transmissions

This parameter allows you to select the number of transmissions for each message. For example, if 3 is selected, then each message will be transmitted three times. The time between each transmission will be a random time between 0.5 and 4 seconds. The valid choices for this option are 1 - 5.

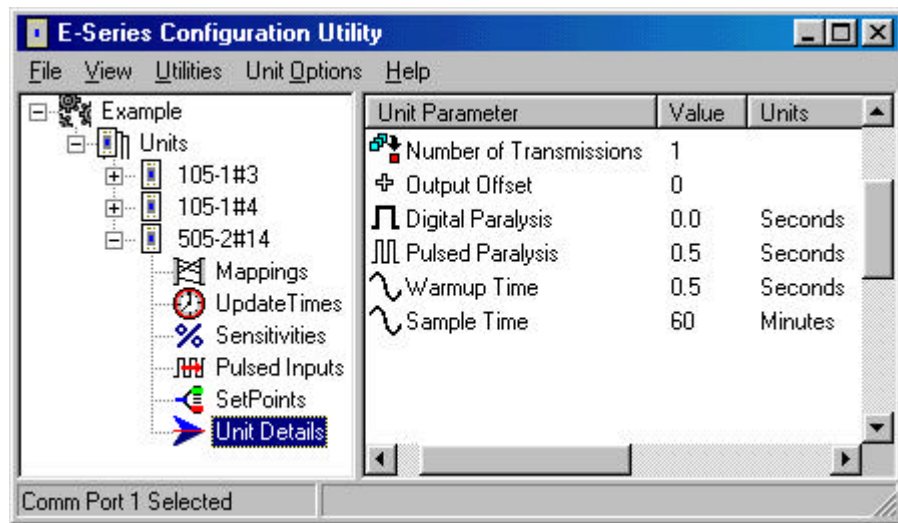

## 4.8 Programming Configurations to Modules

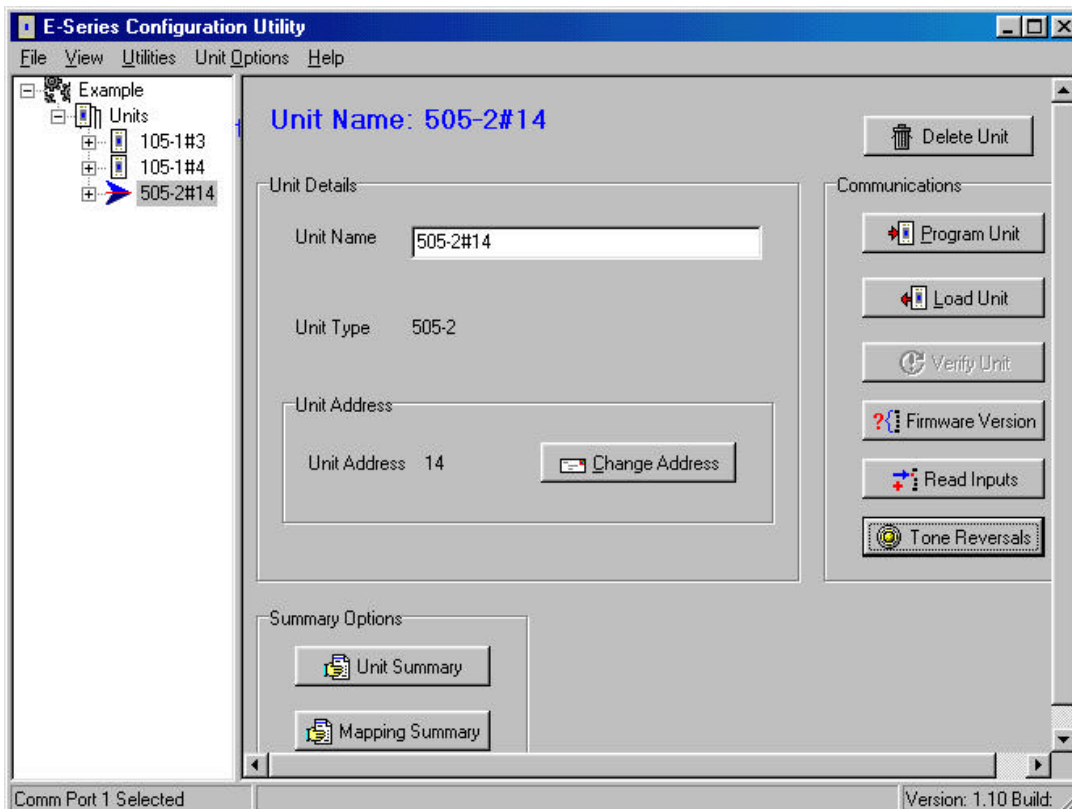

To programme a module :

- Connect the cable from the PC's serial port to the 505U serial port (see 3.5.4 for cable connections)

- From the Utilities menu, select “Serial Port Setup”
- Select the appropriate serial port (COM1 - COM4)
- Select the unit to be configured from the left-hand menu
- Click on the “Program Unit” button.

You will be asked to confirm if the module already has a different system or unit address.

Each module will need to be programmed individually.

## **4.9 Loading Configuration from a Module**

Care should be taken when loading a configuration from a module. It is easy to lose the system address and unit address. We suggest that you first view the system address and unit address - you can do this via the “Unit Options” menu. Note these addresses before loading the configuration.

When you upload the configuration, the program will check if you want to load the addresses from the module. If you do not, then the system address and unit address will change.

## **4.10 Print Options**

You can obtain a print-out of each module configuration. On each unit display, there are “Unit Summary” and “Mapping Summary” windows. Each of these will display a printable information page about that module. The Unit Summary page will display the user options configured, and the Mapping Summary will display the mappings entered for that unit.

The printer may be selected from the Printer Setup option in the File menu.

## 5 TROUBLESHOOTING

### System Problems

Most problems relate to incorrect configuration, or radio path problems. Before installing the 505U module, "bench-test" its operation with the receiving 105U module alongside. If the 505U does not work properly in this test, it will not work properly installed. If problems are found, check the configuration.

If the bench-test is successful, however problems are experienced after installation, check the radio path (refer to the 105 User Manual for radio path testing).

The 505U provides the following diagnostic features which will help to identify problems.

### LED Indicators.

Normally the green OK LED on the front panel will flash briefly every 10 seconds. When the OK LED extinguishes a sleepmode state is indicated conserving the 505U's battery power. If the OK LED does not flash, a flat battery condition or an internal failure may exist. If the 505U module is located outside, then it will be difficult to see when the LED indicators are on. Remove the front lid of the 505U to see the LED's better.

The yellow TX LED will flash whenever a radio transmission occurs.

### Table of indicator conditions

INDICATOR	CONDITION	MEANING
OK LED ON	Flashes briefly	Normal Operation
OK LED OFF	Continuously	Battery Voltage low CPU failure
OK LED ON	Continuously	Analogue loop on Configuration cable connected
TX LED ON	Flashes briefly	Radio transmitting

### Internal Battery Supply

A battery voltage of 3.0 volts or less indicates new batteries are required Measure the voltage across all three batteries. The 505U module will stop operating if the battery voltage falls below 2.7 volts while transmitting.

Configuration data will not be lost when batteries are removed. When the batteriea are replaced, the low battery status may need to be reset. This is done by connecting the module to the configuration program and selecting "Read Inputs" - select "Battery Status Reset". If the

configuration program is not available, remove the old batteries and leave the new batteries out of the module for approx 30 minutes.

### Diagnostic Features

The configuration software provides some diagnostic features to help identify problems. To use these features, connect the 505U to a PC using a RS232 cable and run the configuration software. The OK LED will light continuously once the module is in configuration mode.

*Note : The OK LED will generally not light continuously unless the cable is in place and the configuration software is running.*

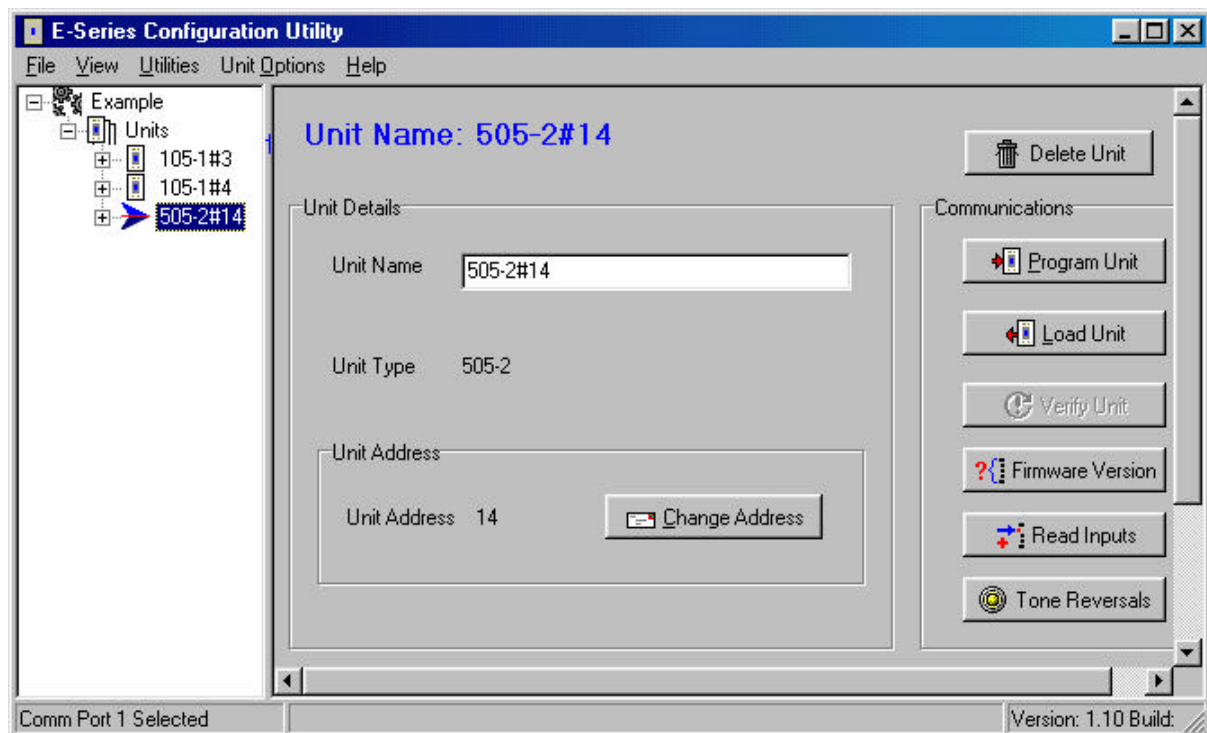

### Read Inputs

This option provides a display of the measured input signals in the 505U, both internal and external. Digital inputs (internal and external) are displayed as "ON" or "OFF", the pulse input accumulated count values are displayed and the analogue input value is displayed in mA. The analogue input value is only updated when the configured analogue sample occurs.

The displayed values will only update when you select "Update".

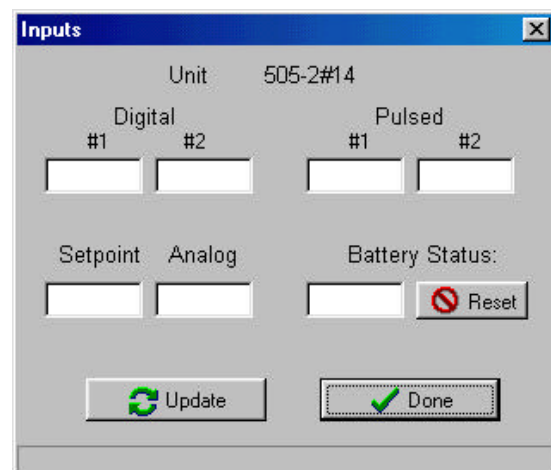

### **Tone Reversals**

This feature turns the radio transmitter on continuously for radio path testing. A series of 1 and 0 data bits is transmitted. This feature is not recommended for 505U-B versions as it will significantly reduce the life of the batteries.

To do radio path testing, refer to the 105 User Manual.

### **Firmware Version**

The feature will display the firmware (software) version of the 505U module.

## 6 SPECIFICATIONS

<b>General</b>		
EMC approval	EN55022 (CISPR 22) - CLASS B EN 50082-1 I-ETS 300 683 AS 3548	89/336/EEC
Radio approval	EN-300-220 AS 4268.2 AUST RFS29 NZ	405 - 490 Mhz, 10 - 500 mW 472 Mhz, 100 mW EIRP 458 Mhz, 500 mW EIRP
Housing	160 x 64 x 36mm IP66	Industrial-grade painted aluminium
I/O & Power Connection	Weatherproof bayonet connector Conxall 6282-7SG-522	Suitable for 0.75 mm <sup>2</sup> conductors Matching female part supplied with unit
LED indication	Transmit, Operation OK, Configuration mode, Reading analogue	
Operating Temperature	-40 to 60 degrees C	
<b>Power Supply</b>		
External Battery supply	11.5 - 15.0 V DC	Overvoltage, reverse power protected
Internal Battery supply	3 x AA 3.5V Lithium 3 x AA 1.5V alkaline External battery pack (optional)	Eveready L91 or equivalent Duracell MN1500B4 or equiv. 3.5 – 5 VDC

Current Drain	120 $\mu$ A 10mA + analogue loop current	“Sleep” mode Operating mode
Analogue loop supply	Included	10 - 12V DC 50mA
Low Battery voltage status	Monitored	Can be transmitted to remote modules
<b>Radio Transmitter</b>		
Frequency	405 - 490 Mhz	12.5/20 kHz channel spacing
Synthesised Transmitter - Frequency configurable range	10MHz	Direct frequency modulation
Transmit power	10, 100, 500mW	250mW max. with internal batteries (500mW with 3dB antenna), 100mW max with 2 x AA internal battery supply
Spurious emissions	TX - <-37 dBm	
Frequency Stability	+/- 1.0 kHz	
Expected line-of-sight range	2 km @ 10mW EIRP 5 km @ 100mW EIRP 10 km @ 500 mW EIRP	Range may be extended by using up to 5 intermediate 105U modules as repeaters,
Antenna Connector	Female BNC coaxial	
<b>Serial Ports</b>		
RS232 Port	DB9 female DCE	4800 baud, no parity, 8 data bits, 1 stop bit
Data transmission - digital inputs	On change-of-state + after update period elapsed	Update time configurable 10 secs - 5 days. Separate, faster update time may be configured when input is ON
Data transmission - pulse inputs	Transmitted as pulse count	Transmitted when count change exceeds configured amount, or on time elapsed since last transmission (configurable 10 secs - 5 days)
	2 pulse inputs may be configured to a single count	Suitable for quadrature or incremental shaft encoders.

Data transmission - analogue input	On change-of-state + after update period elapsed	Sample time configurable 10 secs - 5 days. Change of state sensitivity configurable 0.05 to 20mA. Update time configurable 10 secs - 5 days.
Protocol	Addressed data frame with 16 bit CRC, synchronous DFSK	Each transmission may be configured to be sent 1 - 5 times
<b>Inputs</b>		
Digital Inputs	2 inputs	Suitable for voltage free contacts or NPN transistor, input debounce 0.5 second
Pulse Inputs	505U-2 - 2 inputs	Share digital inputs. Max rate 100Hz, min. pulse width 3ms.
Analogue Input	One 0 - 20 mA (suitable for 4 - 20 mA, 0 - 10mA)	“floating” differential input, common mode voltage 15V. 10 - 12V DC for powering external loops provided, 25 mA max. Resolution 12 bit, Accuracy < 0.1%. Transducer warm-up time configurable 1 - 255 seconds.
Analogue Input Setpoint		Configurable high & low setpoint may be transmitted to remote units, allowing set/reset of remote digital outputs
<b>System Parameters</b>		
Network Configurations	Max. number of 505U inputs is >20 000 if 105U- C modules are used as receivers.	505U is compatible with 105U radio telemetry units which may be used as repeaters, provision of outputs, or as network master unit to connect to PLC or PC
User Configuration		Configuration Software
<b>Diagnostics</b>		
On board diagnostics	Automatic check on startup	Microprocessor operation OK

Diagnostics included in configuration software		Input status, test transmission signal
--	--	--

## 7 WARRANTY

We are pleased that you have purchased this product. We warrant the product against defects for a 365 day warranty period, commencing from the date of purchase.

This warranty does not extend to:

- Failures caused by the operation of the equipment outside the particular product's specification.
- use of the 505U module not in accordance with this User Manual, or
- abuse, misuse, neglect or damage by external causes, or
- repairs, alterations, or modifications undertaken other than by an authorised Service Agent.

Full product specifications and maintenance instructions are available from your Service Agent, your source of purchase, or from the master distributor in your country upon request and should be noted if you are in any doubt about the operating environment for your equipment purchase

In the unlikely event of your purchase being faulty, your warranty extends to free repair or replacement of the faulty unit, after its receipt at the master distributor in your country. Our warranty does not include transport or insurance charges relating to a warranty claim.

This warranty does not indemnify the purchaser of products for any consequential claim for damages or loss of operations or profits.

Should you wish to make a warranty claim, or obtain service, please forward the module to the nearest authorised Service Agent along with proof of purchase. For details of authorised Service Agents, contact your sales distributor.