

Albedometers

FOR THE PRECISE MEASUREMENT OF GLOBAL RADIATION AND ALBEDO

Specifications to ISO 9060 and IEC 60904 standards

Measure incoming and reflected solar radiation with one convenient instrument

Used around the world in meteorology, hydrology and climate research

Easily portable for field research

INTRODUCTION

The albedo of a surface is the extent to which it diffusely reflects short-wave radiation from the sun in the wavelength range from 300 to 3000 nanometers (nm). It is the ratio of the reflected radiation to the incoming radiation and varies from 0 (dark) to 1 (bright). As an indication, albedo is about 0.15 for grass, 0.5 for dry sand and 0.8 for fresh snow.

An Albedometer consists of two pyranometers. The upper sensor measures incoming global solar radiation and the lower sensor measures solar radiation reflected from the surface below. When the two signal outputs have been converted to irradiance in W/m², the albedo can be simply calculated.

Kipp & Zonen has been manufacturing pyranometers for over 75 years and our CMA albedometers share this experience and technology. They comply with the requirements of ISO 9060 and are fully traceable to the World Radiometric Reference (WRR) in Davos, Switzerland, where Kipp & Zonen instruments form part of the World Standard Group.

APPLICATIONS

Kipp & Zonen albedometers have been developed for use in all environments, from the Antarctic to deserts. They are installed around the world for meteorology, hydrology, climate research, and agriculture. A particular use is for measuring the changing albedo of glaciers, snow and ice fields in climate change research.

Kipp & Zonen CMA albedometers are convenient all-in-one instruments designed for a long operating life with simple maintenance and the light weight is ideal for portable applications.

CHOICE OF ALBEDOMETER

The most appropriate model for an application depends on the desired accuracy and performance. CMA albedometers have broadband thermopile detectors and double glass domes, an integrated bubble level and a white sun shield to prevent the body heating up. The waterproof connector has gold-plated contacts and is fitted with 10m of high quality signal cable as standard. The instruments do not require power and are supplied with calibration certificates traceable to the WRR.

CMA 6 is an ISO First Class albedometer that uses two CMP 6 pyranometer detector assemblies built into a single housing. An integrated glare screen prevents direct illumination of the lower domes at sunrise and sunset, and a screw-in drying cartridge keeps the interior free from humidity. A mounting rod is fitted to provide easy attachment to a mast.

Its good quality and cost-effectiveness make CMA 6 ideal for meteorology, hydrology and agriculture.

CMA 11 is a double CMP 11 pyranometer that complies with the highest level of ISO classification, Secondary Standard. It has all the features of the CMA 6 but uses higher quality glass domes and a faster response detector design with temperature compensation.

CMA 11 is recommended for scientific applications, for which accuracy needs to be according to the highest standards.

OTHER CONFIGURATIONS

An entry level albedometer can be configured by using two CMP 3 pyranometers and the accessory mounting rod. Highest performance albedometers can be assembled using two CMP 21 or CMP 22 pyranometers and a CMF 1 mounting fixture. Ventilated setups are also possible.

Go to www.kippzonen.com for more information.

Specifications	CMA6	CMA11
ISO CLASSIFICATION	First Class	Secondary Standard
Response time (95%)	<18 s	<5 s
Non-linearity (0 to 1000 W/m ²)	<1%	<0.2%
Tilt error (at 1000 W/m ²)	<1%	<0.2%
Temperature dependence of sensitivity	<4% (-10 to +40°C)	<1% (-10 to +40°C)
Sensitivity	5 to 20 $\mu\text{V}/\text{W}/\text{m}^2$	7 to 14 $\mu\text{V}/\text{W}/\text{m}^2$
Impedance	20 to 200 Ω	10 to 100 Ω
Operating temperature	-40 to +80°C	-40 to +80°C
Spectral range (50% points)	310 to 2800 nm	310 to 2800 nm
Maximum irradiance	2000 W/m ²	4000 W/m ²
Directional error (at 80° with 1000 W/m ²)	<20 W/m ²	<10 W/m ²
Weight (including rod & cable)	1.2 kg	1.2 kg

The CMA series have a standard cable length of 10 m. Optional cable lengths 25 m and 50 m.

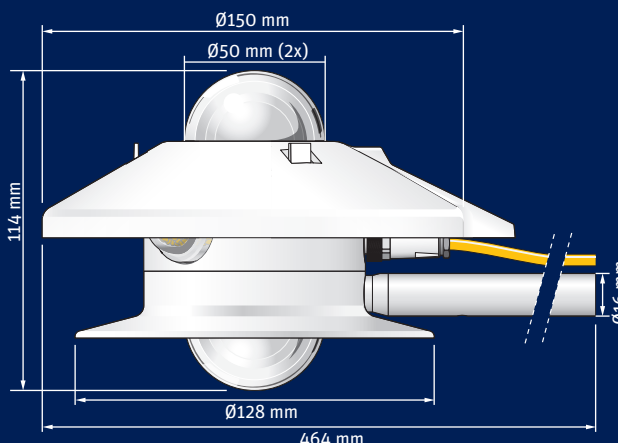

Go to www.kippzonen.com for your local distributor

HEAD OFFICE

Kipp & Zonen B.V.
 Delftechpark 36, 2628 XH Delft
 P.O. Box 507, 2600 AM Delft
 The Netherlands
 T: +31 (0) 15 2755 210
 F: +31 (0) 15 2620 351
info@kippzonen.com

Kipp & Zonen B.V. reserve the right to alter specifications of the equipment described in this documentation without prior notice